

Flyer

Kardex VCM Box

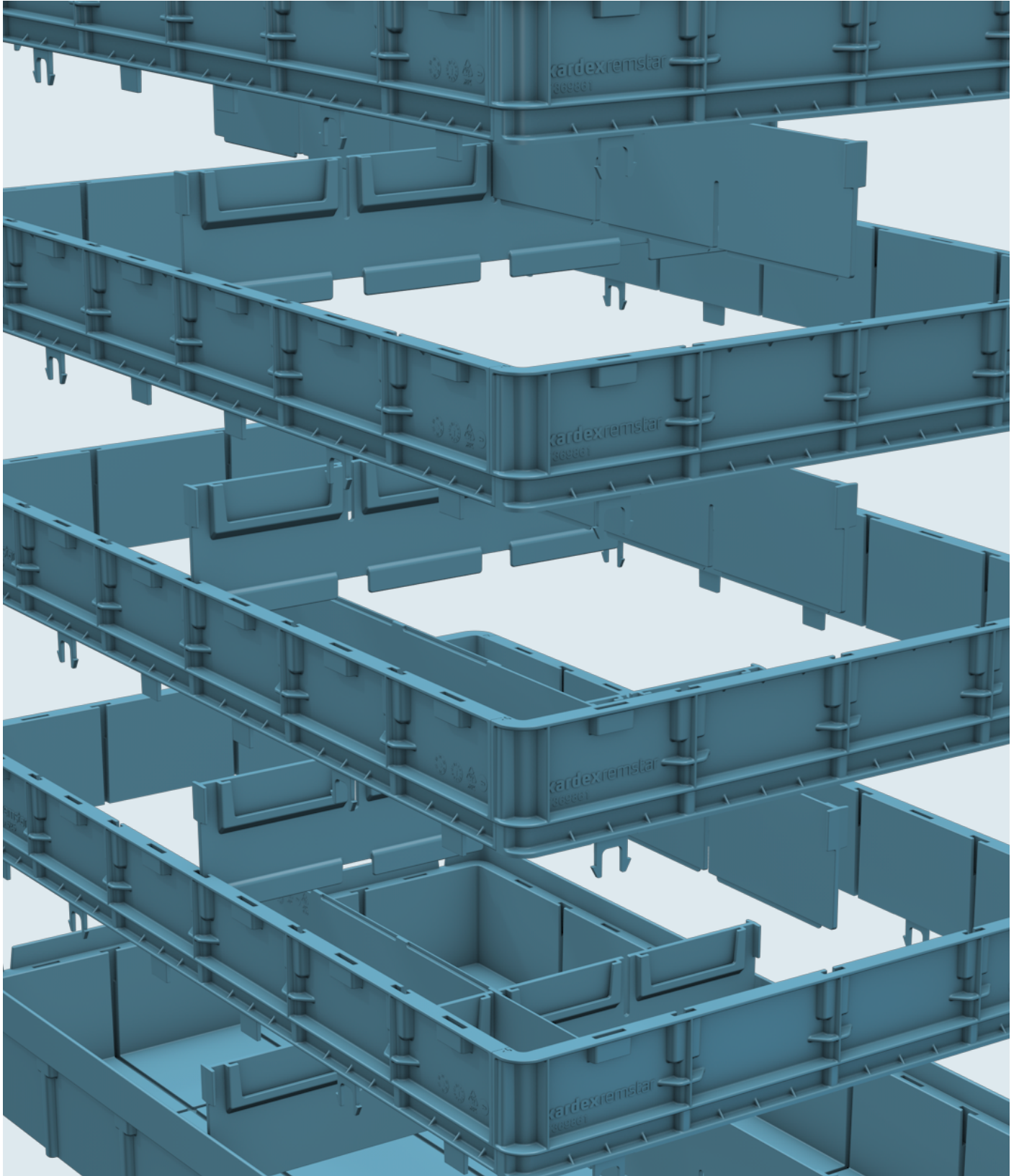

VCM Box Base

The base box is the most important component, as all other frames and dividers are based on this box.

The VCM Box, tailor-made for the Kardex Vertical Carousel Module (VCM), ensures a flexible, customized, and organized storage solution. It is available either with a width of 200 mm or 400 mm, each with a depth of 625 mm. The base box can be adjusted with different frames and dividers to create individual storage locations for various items. Fixed label holders are already integrated in the front area.

With an ergonomically shaped handle and a slight elevation in the longitudinal direction at the bottom of the box, the VCM Box can quickly and comfortably pull out of the carrier and push back in smoothly. The two bars in the front area of the box are specifically there to utilize the full depth of the carrier. The bars prevent the box from slipping over the carrier. Thanks to a slight incline in the lower area of these bars, it is also possible to pull the box ergonomically and without great effort also easy over the front lip of the carrier.

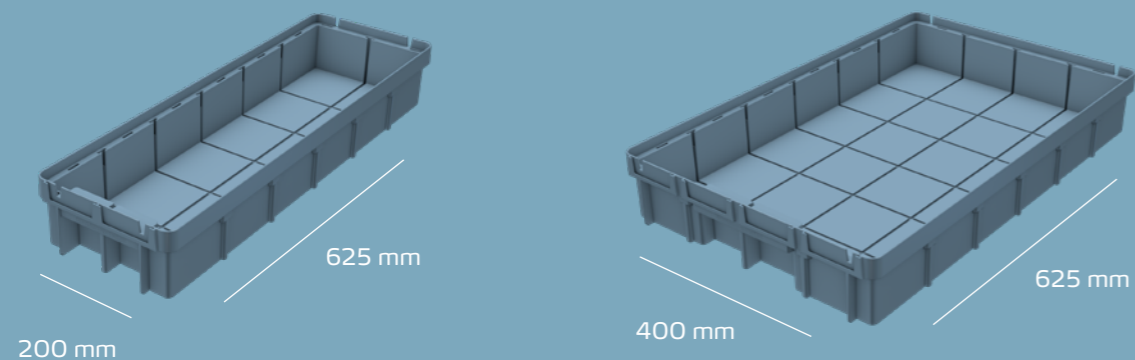

Unique frame system

The Kardex VCM Box is recognized by its frame concept. The Kardex unique and smart EasyClick system allows the possibility to build up the VCM Box base to different heights. It always adapts to maximize Kardex's VCM Box volume. The VCM Box is extremely flexible and will adapt to your future needs. It is possible to change its height by adding or reducing frames.

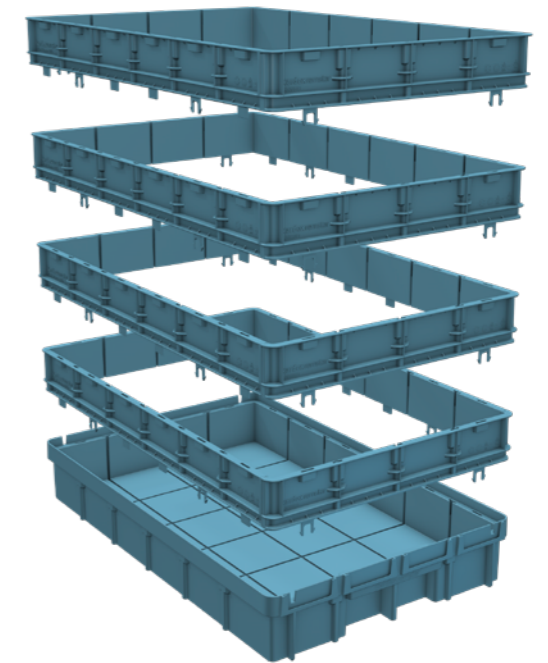

Flexible
and scalable
box system

Optimally
adapts to
customer's
needs

Effective
use of available
storage space

Flexible divider system

Kardex VCM Boxes flexibly divide and quickly adapt at any time by using cross and longitudinal dividers.

The individual divider concept creates different combinations in order to reach the desired height.

This creates individual storage locations and enhances flexibility as well as scalability of the box to deliver a complete storage and classification system. This further ensures maximum storage volume and high-density storage.

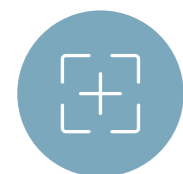

Smart plug-in with EasyClick system

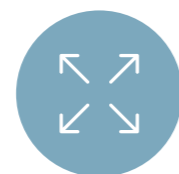

Highly-flexible height, width, and depth



Environmentally friendly

Technical data

Dimensions VCM Box	VCM Box 6-2-1	VCM Box 6-4-1
	Outside 625 × 200 × 95 mm Inside 598 (582) × 175 × 87 mm	Outside 625 × 400 × 95 mm Inside 598 (582) × 375 × 87 mm

Weight (empty box)	VCM Box 6-2-1	VCM Box 6-4-1
	788 g	1250 g

Volume	VCM Box 6-2-1	VCM Box 6-4-1
	9,14 l	19,59 l

Elevation grid of the frames	95 mm	(base box)
	145 mm	(base box + 1 frame)
	210 mm	(base box + 2 frame)
	275 mm	(base box + 3 frame)
	340 mm	(base box + 4 frame)
	405 mm	(base box + 5 frame)
470 mm	(base box + 6 frame)	

Elevation grid of dividers	95 mm	(1 divider 95 mm)
	145 mm	(1 divider 145 mm)
	210 mm	(1 divider 145 mm + 1 divider 65 mm)
	275 mm	(1 divider 145 mm + 2 divider 65 mm)
	340 mm	(1 divider 145 mm + 3 divider 65 mm)
	405 mm	(1 divider 145 mm + 4 divider 65 mm)
470 mm	(1 divider 145 mm + 5 divider 65 mm)	

Material	Polypropylen (PP)
-----------------	-------------------

Colour	Blue
---------------	------

Payload	Up to 35 kg
----------------	-------------

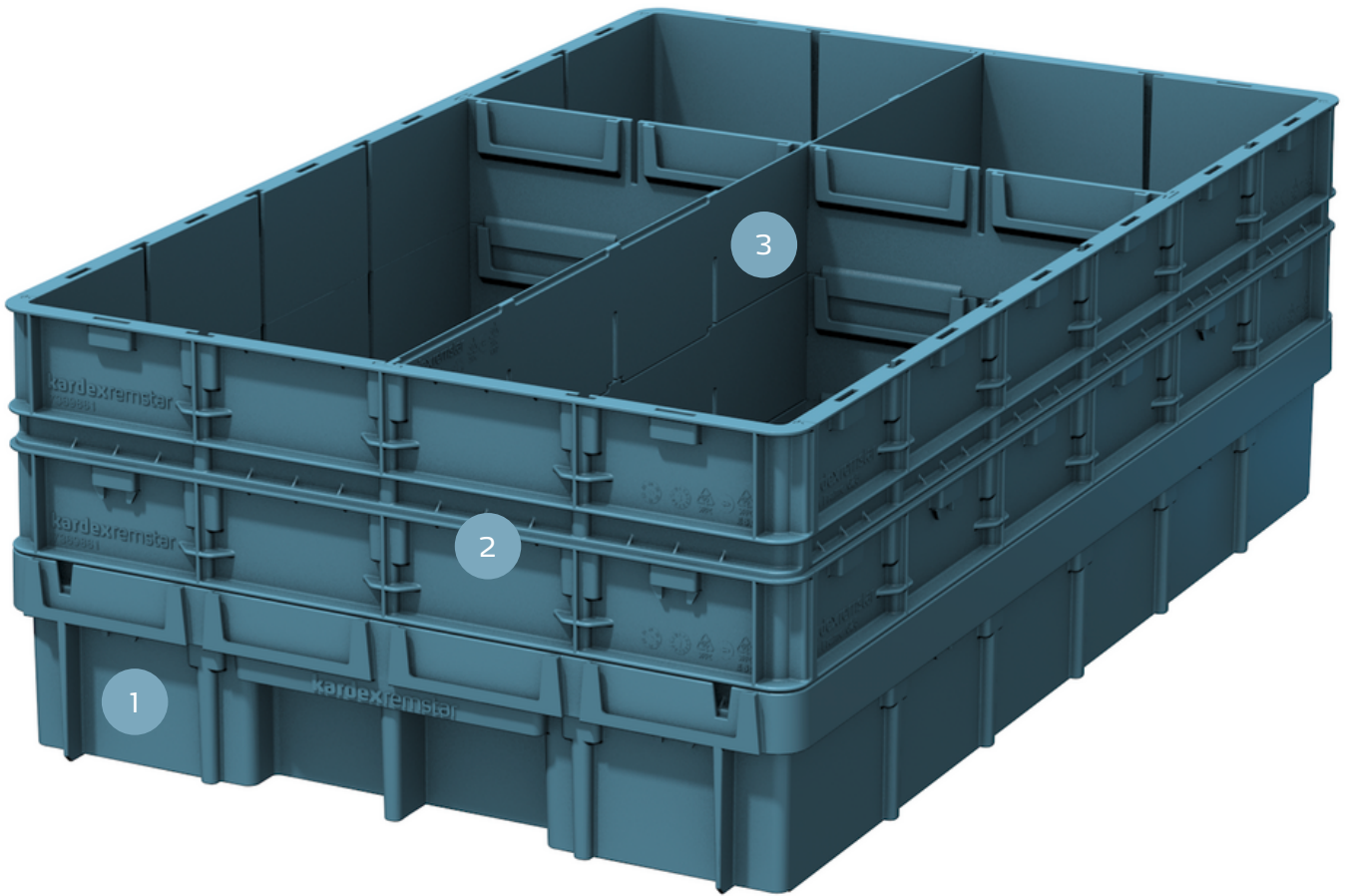

1 Base Box

The basic box is the most important unit in the VCM Box concept, as all other frames and dividers are based on this box.

2 Frames

With an EasyClick system, the frames can be placed on the base box and plugged into each other to be able to adjust the height of the box quickly and flexibly.

3 Divider

This concept further increases the flexibility of the box in order to provide a comprehensive storage and classification system for the Vertical Carousel Module.



Contact us

[kardex.com](https://www.kardex.com)